

FREIN

FREIN A AIR



MEMBRANE



NO.	TYPE	
418-1-056	12	5-7/16"
418-1-057	16	6-3/8"
418-1-058	20	6-9/16"
418-1-059	24	7"
418-1-060	30	7-13/16"
418-1-061	36	8-7/8"

NO.	TYPE		COURSE
418-12-012	12	SIMPLE	2.5"
418-12-016	16	SIMPLE	2.5"
418-12-015	20	SIMPLE	2.5"
418-12-024	24	SIMPLE	2.5"
418-12-030	30	SIMPLE	2.5"
418-12-026	36	SIMPLE	2.5"

NO.	TYPE		COURSE
418-12-020	30/30	DOUBLE	2.5"
418-12-110	30/30	DOUBLE	3"
418-12-019	30/30	INTRAAX	2.5"
418-12-119	30/30	INTRAAX	3"

BOUCHON BLEU



418-12-022

COUVERCLE PARE-POUSSIÈRE



418-12-005

TROUSSE POUR TENDEUR



TROUSSE POUR TENDEUR

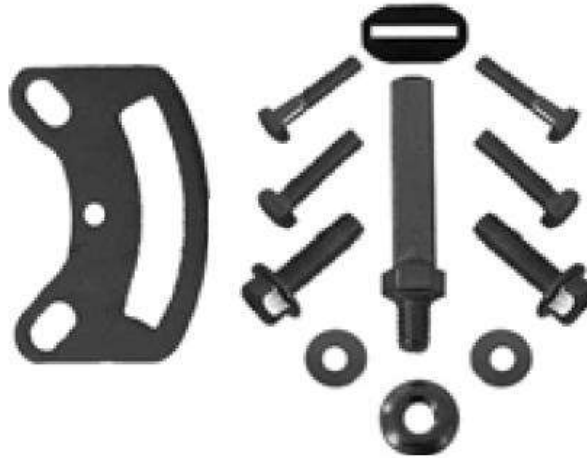

BRIDES



NO.	TYPE
418-1-067	12
418-1-066	16
418-1-065	20
418-1-063	24
418-1-062	30
418-1-064	36

HA-427-10558

HALDEX

HA-427-10563

HALDEX

CHAPE/GOUPILLE



CHAPE/GOUPILLE



CHAPE/GOUPILLE MERITOR



CHAPE	418-1-086	5/8"
	418-1-107	1/2"
	418-1-108	1/2" ALLONGÉE

GOUPILLE	418-1-083	1/2"
	418-1-085	5/8"

418-13-020	GUNITE AS-3000
------------	----------------

RW-R810005	ENS. GOUPILLES
RW-R810009	ENS. CHAPE & GOUPILLES

TIGE DE RELÂCHE



418-1-049	COURSE 2-1/2"
418-1-050	COURSE 3"

FREIN TENDEUR DE FREIN

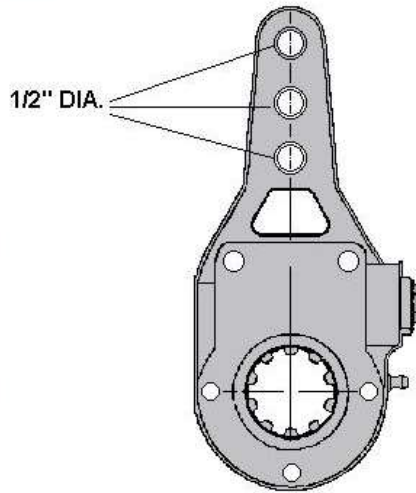

	CANNELURE	DU CENTRE À LA DOUILLE	ENSEMBLE NO.
REMORQUE	1-1/2-28	5" 6" 7"	418-8-181
CAMION	1-1/2-28	5-1/2" 6-1/2"	418-8-184
REMORQUE	1-1/2-10	5" 6" 7"	418-8-180
CAMION	1-1/2-10	5-1/2" 6-1/2"	418-8-183
REMORQUE	1-5/8-37	6"	418-8-182
	DOUILLE	GOUPILLE 1/2"	BX-201225
	DOUILLE	GOUPILLE 5/8"	BX-211573

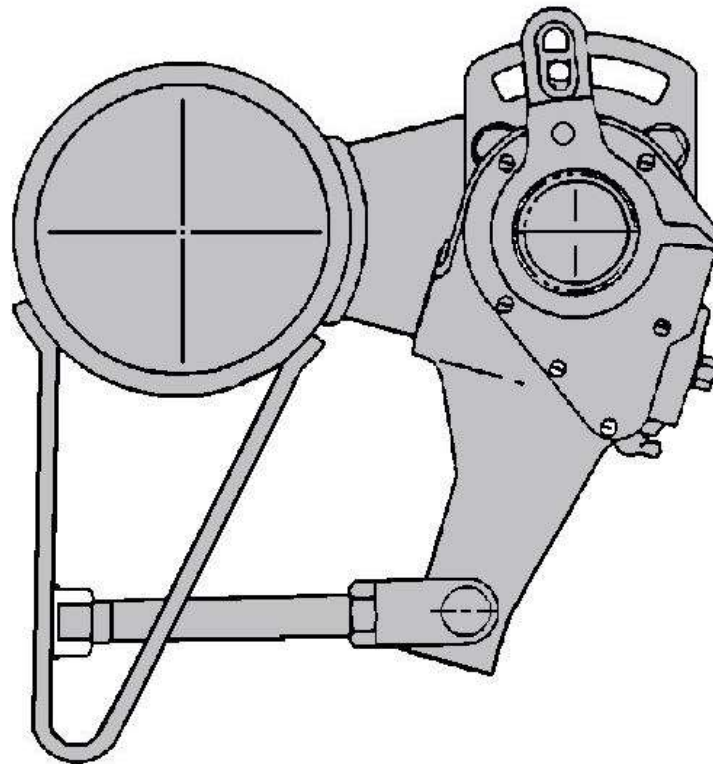

HALDEX

CANNELURE	DU CENTRE À LA DOUILLE	ENSEMBLE NO.
1-1/2-28	6"	HA-400-10212
1-1/2-28	5-1/2"	HA-400-10211
1-1/2-10	6"	HA-400-10216
1-1/2-10	5-1/2"	HA-400-10215
1-5/8-37	6"	HA-400-10214
1-1/2-28	5-1/2"	HA-400-10141

GÉNÉRIQUE

CANNELURE	DU CENTRE À LA DOUILLE	ENSEMBLE NO.
1-1/2-28	6"	418-14-281
1-1/2-28	5-1/2"	418-14-286
1-1/2-10	6"	418-14-280
1-1/2-10	5-1/2"	418-14-285
1-5/8-37	6"	418-14-282
1-1/2-28	5-1/2"	418-14-284

FREIN

TENDEUR DE FREIN

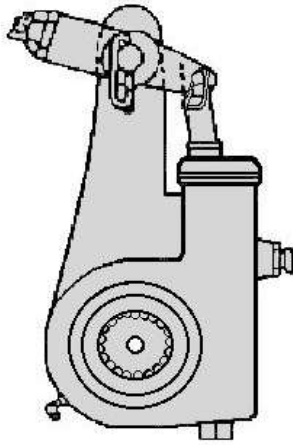

MERITOR

CANNELURE	DU CENTRE À LA DOUILLE	ENSEMBLE NO.
1-1/2-28	6"	RW-R803112
1-1/2-28	5-1/2"	RW-R803110
1-1/2-10	6"	RW-R803106
1-1/2-10	5-1/2"	RW-R801041
1-5/8-37	6"	RW-R803116

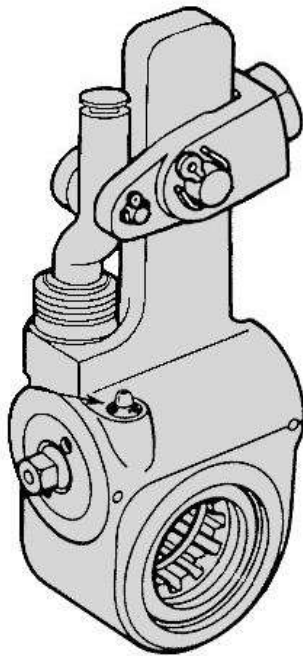

GUNITE

CANNELURE	DU CENTRE À LA DOUILLE	ENSEMBLE NO.
1-1/2-28	6"	418-13-281
1-1/2-28	5-1/2"	418-13-284
1-1/2-10	6"	418-13-280
1-1/2-10	5-1/2"	418-13-283
1-5/8-37	6"	418-13-282

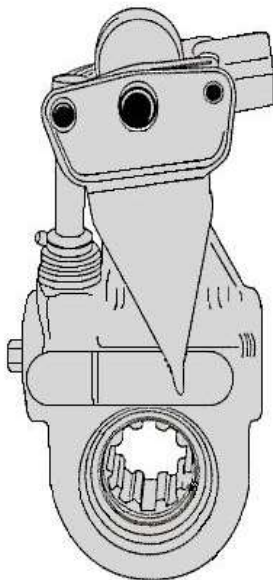

STEMCO (CREWSON-BRUNER)

CANNELURE	DU CENTRE À LA DOUILLE	ENSEMBLE NO.
1-1/2-28	6"	418-8-281
1-1/2-28	5-1/2"	418-8-284
1-1/2-10	6"	418-8-280
1-1/2-10	5-1/2"	418-8-283
1-5/8-37	6"	418-8-282

FREIN

ARBRE A CAME

**HENDRICKSON
FREIN "ES" 16-1/2'**

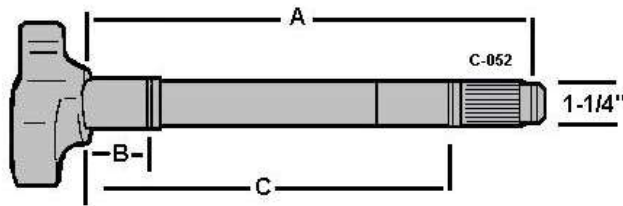

MAIN GAUCHE

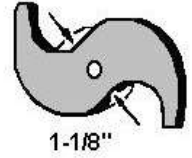

1-1/2" DIAM. - 28 CANNELURES

NO.	REPLACEMENTS	A	B	C
CAM-12032L	HENDRICKSON S-24636-1L	11-1/16"	2-5/16"	8-11/16"
CAM-12033R	HENDRICKSON S-24636-1R			

1-1/2" DIAM. - 10 CANNELURES

NO.	REPLACEMENTS	A	B	C
CAM-12034L	HENDRICKSON S-23857-1L	11-1/16"	2-5/16"	8-11/16"
CAM-12035R	HENDRICKSON S-23857-1R			

"A" DIMENSION
Mesurer de l'intérieur de
la tête jusqu'au début
de la rainure de la barrure

**EATON
FREIN XL
15" & 16-1/2"**

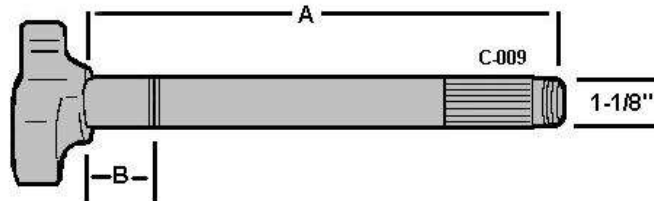

MAIN GAUCHE

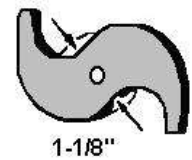

1-1/2" DIAM. - 10 CANNELURES

NO.	REPLACEMENTS	A	B
CAM-10294L	EATON 807858	10-9/16"	1-3/4"
CAM-10295R	EATON 807859		
CAM-10430L	EATON 808068	13-1/2"	1-3/4"
CAM-10431R	EATON 808069		

"A" DIMENSION
Mesurer de l'intérieur de
la tête jusqu'au début
de la rainure de la barrure

**EATON
FREIN AX 15"**

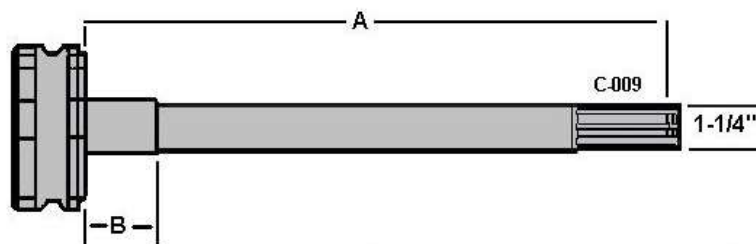

MAIN GAUCHE

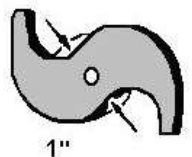

1-1/4" DIAM. - 10 CANNELURES

NO.	REPLACEMENTS	A	B
CAM-10502L	EATON 811668	15-3/4"	1-3/4"
CAM-10503R	EATON 811669		

"A" DIMENSION
Mesurer de l'intérieur de
la tête jusqu'au début
de la rainure de la barrure

FREIN

ARBRE A CAME

**STANDARD
FREIN 16-1/2"**

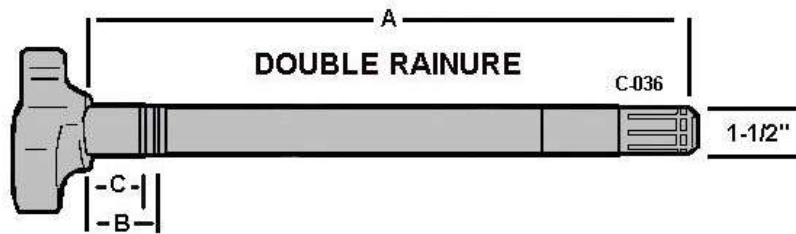

MAIN GAUCHE

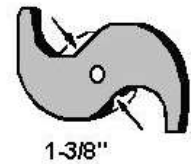

NO.	A	B	C
CAM-10506L	20-3/8"	2-7/32"	1-5/8"
CAM-10507R			
CAM-10522L	23-7/16"	2-7/32"	1-5/8"
CAM-10523R			

1-1/2" DIAM - 10 CANNELURES

"A" DIMENSION
Mesurer de l'intérieur de
la tête jusqu'au début
de la rainure de la barrure

**SPICER
FREIN 16-1/2"
"XL"**

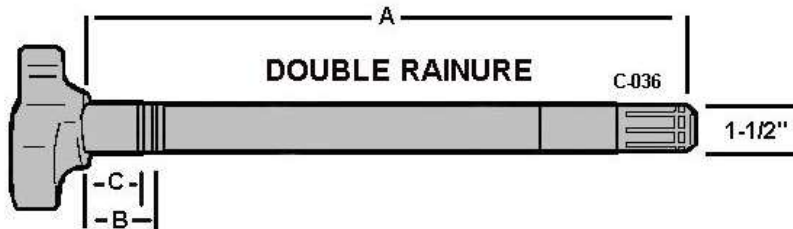

MAIN GAUCHE

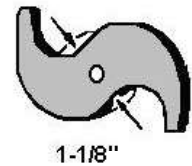

NO.	A	B	C
CAM-Q10505L	20-3/8"	2-7/32"	1-5/8"
CAM-Q10507L			
CAM-Q10522L	23-7/16"	2-7/32"	1-5/8"
CAM-Q10523R			

1-1/2" DIAM - 10 CANNELURES

"A" DIMENSION
Mesurer de l'intérieur de
la tête jusqu'au début
de la rainure de la barrure

**SPICER
FREIN 16-1/2"
"XL"**

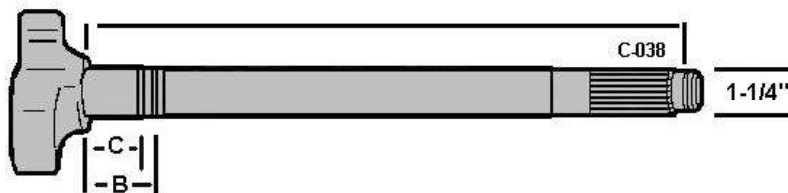

MAIN GAUCHE

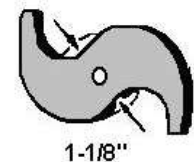

NO.	A	B	C
CAM-10152L	17-3/8"	2-7/32"	1-5/8"
CAM-10153R			
CAM-10154L	20-3/8"	2-7/32"	1-5/8"
CAM-10155R			
CAM-10158L	23-1/2"	2-7/32"	1-5/8"
CAM-10159R			
CAM-10094L	23-7/8"	2-7/32"	1-5/8"
CAM-10095R			
CAM-10162L	24"	2-7/32"	1-5/8"
CAM-10163R			

1-1/2" DIAM. - 28 CANNELURES

"A" DIMENSION
Mesurer de l'intérieur de
la tête jusqu'au début
de la rainure de la barrure

FREIN

ARBRE A CAME

**SPICER
FREIN 16-1/2"
"XL"**

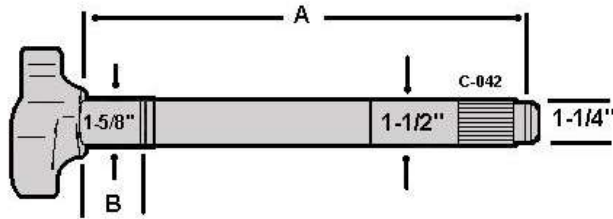

MAIN GAUCHE

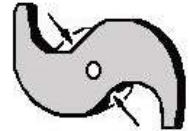

1-1/8"

NO:	A	B
CAM-10172L	23-1/2"	2-7/32"
CAM-10173R		
CAM-10176L	24-1/8"	2-7/32"
CAM-10177R		
CAM-10174L	26-7/8"	2-7/32"
CAM-10175R		

1-1/2" DIAM - 28 CANNELURES

"A" DIMENSION
Mesurer de l'intérieur de
la tête jusqu'au début
de la rainure de la barrure

**MERITOR
FREIN 16-1/2"
"Q PLUS"**

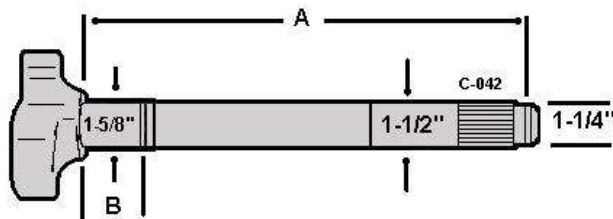

MAIN GAUCHE

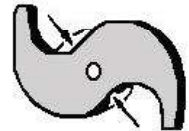

1-1/8"

NO:	A	B
CAM-Q10354L	24-1/8"	1-63/64"
CAM-Q10355R		
CAM-Q10312L	11-9/16"	1-13/16"
CAM-Q10313R		

1-1/2" DIAM - 28 CANNELURES

"A" DIMENSION
Mesurer de l'intérieur de
la tête jusqu'au début
de la rainure de la barrure

**INGERSOL
FREIN 16-1/2"**

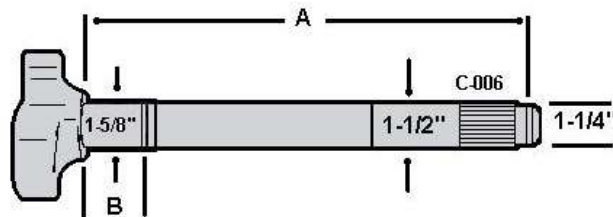

MAIN GAUCHE

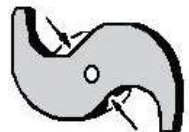

1-3/8"

NO.	A	B
CAM-10916L	23-7/8"	2-1/4"
CAM-10917R		

1-1/2" DIAM - 28 CANNELURES

"A" DIMENSION
Mesurer de l'intérieur de
la tête jusqu'au début
de la rainure de la barrure

FREIN

ARBRE A CAME

**SPICER
FREIN
16-1/2" & 18"**



DOUBLE RAINURE

MAIN GAUCHE

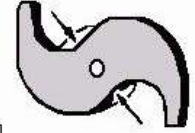

1-3/8"

1-1/2" DIAM - 28 CANNELURES

"A" DIMENSION
Mesurer de l'intérieur de
la tête jusqu'au début
de la rainure de la barrure

NO.	A	B	C
CAM-10422L	23-1/2"	2-7/32"	1-5/8"
CAM-10423R			

**MERITOR
FREINS 16-1/2"**

MAIN GAUCHE

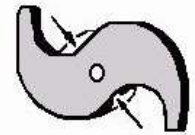
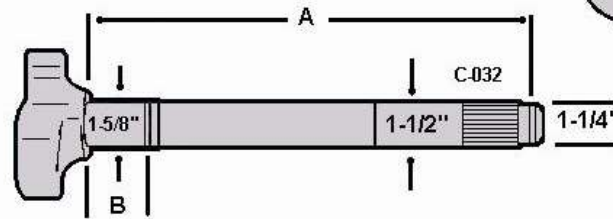

1-3/8"

1-1/2" DIAM - 28 CANNELURES

"A" DIMENSION
Mesurer de l'intérieur de
la tête jusqu'au début
de la rainure de la barrure

NO.	A	B
CAM-10854L	17-5/16"	1-63/64"
CAM-10855R		
CAM-10856L	20-13/32"	1-63/64"
CAM-10857R		
CAM-10858L	24-1/16"	1-63/64"
CAM-10859R		
CAM-10758L	24-1/16"	1-23/32"
CAM-10759R CAM-10859R		
CAM-10758L	24-1/16"	1-23/32"
CAM-10759R		

ENCEINTE D'ARBRE A CAME

TROUSSE POUR ENCEINTE D'ARBRE



ENCEINTE



DIA. INT	LONG
1-1/2"	17-3/4"

DIA. INT	LONG
1-1/2"	21"

REPLACE
ROCKWELL
SPICER-TA31-1401
46-4-095

REPLACE
ROCKWELL
SPICER-TA31-1402
46-4-096

HENDRICKSON S26348	intérieur	extérieur
1 ENCEINTE		
2 SUPPORTS D'ARBRE		
2 RONDELLES	2-1/4"	1-1/2"
3 RONDELLES	1-7/8"	1-1/4"
1 JOINT	2-3/8"	1/16"
1 BAGUE DE BLOCAGE		1-3/8"
1 BAGUE DE BLOCAGE		1-1/8"
3 BOULONS 1-1/4" long		3/8"
3 ÉCROUS	3/8" n.c.	

46-6-348

SUPPORT D'ENCEINTE

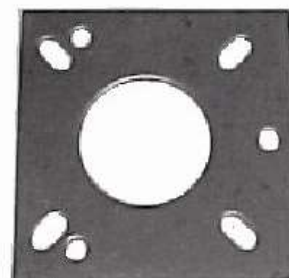



DIA. INT	ÉPAISSEUR
1-7/8"	1/8"

REPLACE
ROCKWELL
SPICER-TA31-1405

46-4-097

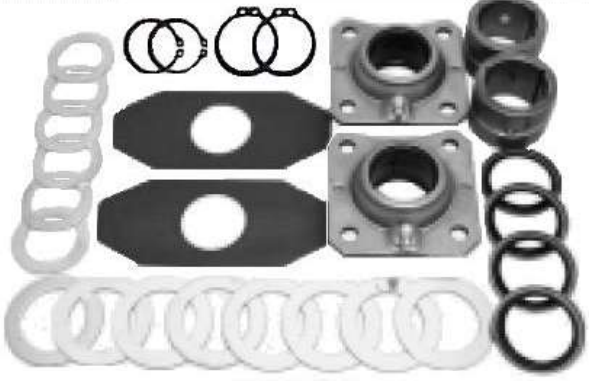
FREIN TROUSSE

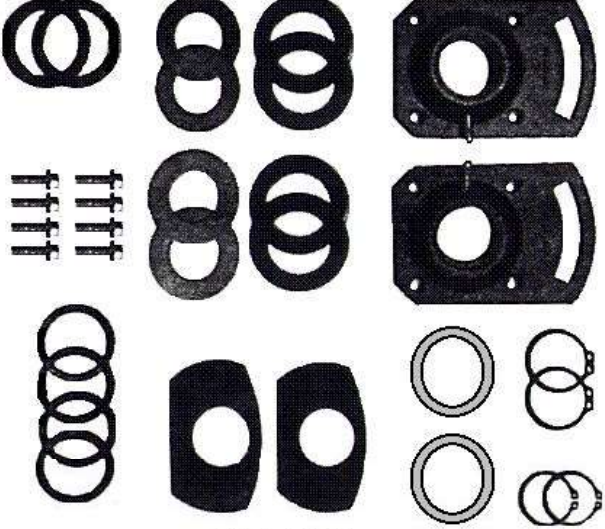
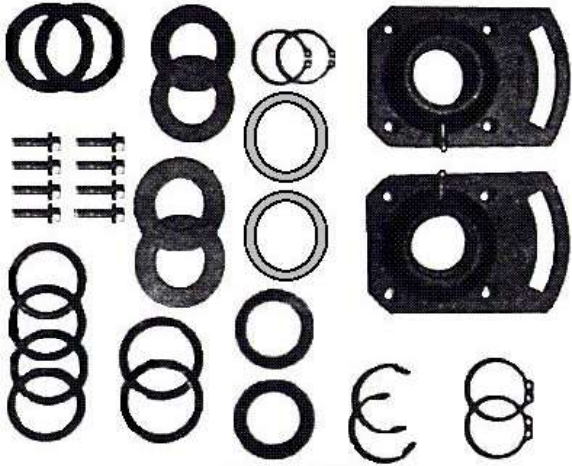
 <p style="text-align: center;">46-6-974</p>	<p>4- JOINTS 2- BAGUES DE BLOCAGE 2- COUSSINETS 6- RONDELLES 2- BAGUES DE BLOCAGE 8- RONDELLES 2- SUPPORTS 2- RONDELLES</p>	<p style="text-align: center;">REPLACEMENT EUCLID E-11450HD HENDRICKSON S-23974</p>
 <p style="text-align: center;">46-1-8773M</p>	<p>2- BAGUES DE BLOCAGE 2- RONDELLES 2- RONDELLES 4- JOINTS 2- BAGUES DE BLOCAGE 2- BAGUES DE BLOCAGE 2- SUPPORTS 2- SUPPORTS 2- RONDELLES 2- RONDELLES</p>	<p style="text-align: center;">REPLACEMENT EUCLID E-9079HC LELAND K-363 SPICER 43-7072</p>
 <p style="text-align: center;">46-4-7117</p>	<p>1- SUPPORT GAUCHE 1- SUPPORT DROIT 2- BAGUES DE BLOCAGE 2- BAGUES DE BLOCAGE 2- COUSSINETS 2- RONDELLES 2- RONDELLES 2- RONDELLES 2- RONDELLES 2- RONDELLES 2- RONDELLES 8- VIS 4- JOINTS</p>	<p style="text-align: center;">REPLACEMENT DANA - 43-7117</p> <p>- 12-1/4" ET 16-1/2" FREINS STANDARD ET " XL"</p> <p>- 1-1/2" DE DIAMÈTRE</p> <p>- COUSSINETS BRONZE</p>
 <p style="text-align: center;">46-4-7118</p>	<p>1- SUPPORT GAUCHE 1- SUPPORT DROIT 2- BAGUES DE BLOCAGE 2- BAGUES DE BLOCAGE 2- BAGUES DE BLOCAGE 2- COUSSINETS 2- RONDELLES 2- RONDELLES 2- RONDELLES 2- RONDELLES 2- RONDELLES 8- VIS 4- JOINTS</p>	<p style="text-align: center;">REPLACEMENT DANA - 43-7118</p> <p>- 12-1/4" ET 16-1/2" FREINS STANDARD ET " XL"</p> <p>- 1-5/8" DE DIAMÈTRE</p> <p>- COUSSINETS BRONZE</p> <p>- NOUVELLE TROUSSE</p>

FREIN

TROUSSE



REPLACEMENT

EUCLID E-6078
 MERITOR KIT8289
 SPICER 43-7072A

46-1-8788

SUPPORT ARBRE À CAME



REPLACEMENT

EUCLID E-1318AHD
 LELAND L-2854
 SPICER 30-1358
 MERITOR A3105V282

46-1-049

SUPPORT ASSEMBLÉ



DIAM. INT. 16-1/2"

REPLACEMENT

EUCLID E-2104
 LELAND L-1198
 SPICER 30-1357
 MERITOR R630003

46-2-005



REPLACEMENT

EUCLID E-2287
 LELAND K-343
 SPICER 43-7035
 MERITOR R615008

46-4-401

PLAQUE DE RETENUE



REPLACEMENT

EUCLID E-2365
 LELAND L-2387
 SPICER 30-1385

46-4-1385

COUSSINET D'ACIER



REPLACEMENT

EUCLID E-6076
 MERITOR KIT1760
 LELAND L-3033/43

46-1-255

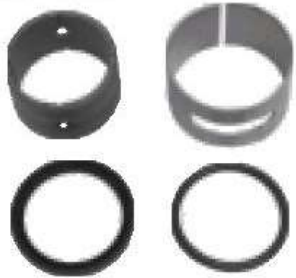

REPLACEMENT

EUCLID E-2670
 MERITOR KIT9034
 LELAND L-1305
 SPICER 28-1243

DIAM. INT. 1-5/8"

46-1-060K

















REPLACEMENT

EUCLID E-2291
 LELAND L-891
 SPICER 28-1255
 MERITOR KIT9036

DIAM. INT. 1-1/2"





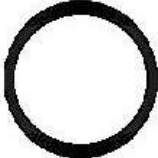
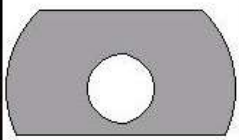









46-1-059K

FREIN COMPOSANTE

<p style="text-align: center;">RONDELLE</p>  <p style="text-align: center;">REPLACE</p> <p>L889 E1113 35-1580 1229B2971 1229B1848</p> <p>Dia.Ext. Dia.Int. Long. 1-7/8" 1-17/64" 2"</p> <p>46-1-016</p>	<p style="text-align: center;">RONDELLE</p>  <p style="text-align: center;">REPLACE</p> <p>E1781 L1608 29-1320 R627006</p> <p>Dia.Ext. Dia.Int. Long. 1/32" 1-1/8" 2"</p> <p>46-3-1320 DIA. 1-1/2"</p>	<p style="text-align: center;">BAGUE BLOPAGE</p>  <p style="text-align: center;">REPLACE</p> <p>E526 L137 1229Z1118</p> <p>Dia.Ext. Dia.Int. Long. 1-31/64" 1/16" 1"</p> <p>46-1-042 DIA. 1-1/2"</p>	<p style="text-align: center;">COUSSINET NYLON</p>  <p style="text-align: center;">REPLACE</p> <p>E759 L1536 R617003</p> <p>Dia.Ext. Dia.Int. Long. 1-7/8" 1-1/2" 1-1/2"</p> <p>46-2-029</p>	<p style="text-align: center;">COUSSINET BRONZE</p>  <p style="text-align: center;">REPLACE</p> <p>L402 E807 R657001</p> <p>Dia.Ext. Dia.Int. Long. 1-7/8" 1-1/2" 1-1/2"</p> <p>46-2-031</p>	<p style="text-align: center;">JOINT</p>  <p style="text-align: center;">REPLACE</p> <p>E1416 L1770 1205M1105</p> <p>Dia.Ext. Dia.Int. Long. 1-7/8" 1-1/2" 3/16"</p> <p>46-4-007</p>
<p style="text-align: center;">REPLACE</p> <p>L193 E581 29-1308 1229Q277</p> <p>Dia.Ext. Dia.Int. Long. 0.32" 1-17/32" 2-1/4"</p> <p>46-1-046 DIA. 1-1/2"</p>	<p style="text-align: center;">REPLACE</p> <p>E1782 L1609 29-1321 R627005</p> <p>Dia.Ext. Dia.Int. Long. 1/16" 1-1/8" 2"</p> <p>46-3-1321 DIA. 1-1/2"</p>	<p style="text-align: center;">REPLACE</p> <p>E801 L397 1229X1116</p> <p>Dia.Ext. Dia.Int. Long. 1-5/8" 1/16" 1"</p> <p>46-1-021 DIA. 1-5/8"</p>	<p style="text-align: center;">COUSSINET NYLON</p>  <p style="text-align: center;">REPLACE</p> <p>E2102 EL1199 R617002</p> <p>Dia.Ext. Dia.Int. Long. 2-15/32" 1-1/2" 1-3/4"</p> <p>46-2-004</p>	<p style="text-align: center;">COUSSINET BRONZE</p> <p style="text-align: center;">REPLACE</p> <p>Dia.Ext. Dia.Int. Long. 1-5/8" 1" 1"</p> <p>46-4-198</p>	<p style="text-align: center;">REPLACE</p> <p>L966 E1416A R627008</p> <p>Dia.Ext. Dia.Int. Long. 1-3/4" 1-1/2" 1"</p> <p>46-1-091</p> <p style="text-align: center;">REPLACE</p> <p>E654 L1726 1205V1556 5V1556</p> <p>Dia.Ext. Dia.Int. Long. 2-1/16" 1-1/2" 1/4"</p> <p>46-1-053</p>
<p style="text-align: center;">REPLACE</p> <p>L895 E1565 29-1322 R627002</p> <p>Dia.Ext. Dia.Int. Long. .060" 1-41/64" 2-3/8"</p> <p>46-5-043 DIA. 1-5/8"</p>	<p style="text-align: center;">REPLACE</p> <p>E564 L120 29-1309 1229J868</p> <p>Dia.Ext. Dia.Int. Long. .060" 1-17/32" 2"</p> <p>46-1-044 DIA. 1-1/2"</p>	<p style="text-align: center;">REPLACE</p> <p>E1569 L897 1229A1119</p> <p>Dia.Ext. Dia.Int. Long. 1-1/2" 1/16" 1"</p> <p>46-1-043 DIA. 1-5/8"</p>	<p style="text-align: center;">COUSSINET NYLON</p>  <p style="text-align: center;">REPLACE</p> <p>E536 L166 122N378</p> <p>Dia.Ext. Dia.Int. Long. 1-7/8" 1-1/2" 1-1/4"</p> <p>46-1-052</p>	<p style="text-align: center;">GAINÉ EXTÉRIEURE MÉTAL</p>  <p style="text-align: center;">REPLACE</p> <p>E2407 L1294</p> <p>Dia.Ext. Dia.Int. Long. 2" 1-7/8" 1-5/16"</p> <p>46-1-061</p>	<p style="text-align: center;">JOINT</p>  <p style="text-align: center;">REPLACE</p> <p>M1096 E1570</p> <p>Dia.Ext. Dia.Int. Long. 1-7/8" 1-1/2" 1/4"</p> <p>46-3-016</p>
<p style="text-align: center;">REPLACE</p> <p>L192 E580 29-1307 1229Q771</p> <p>Dia.Ext. Dia.Int. Long. .060" 1-17/32" 2-1/4"</p> <p>46-1-045 DIA. 1-5/8"</p>	<p style="text-align: center;">RONDELLE</p>  <p style="text-align: center;">REPLACE</p> <p>E5095 1229J3130</p> <p>Dia.Ext. Dia.Int. Long. 1/32" 1-7/8" 1-1/4"</p> <p>46-1-3130 DIA. 1-1/2"</p>	<p style="text-align: center;">BAGUE BLOPAGE</p>  <p style="text-align: center;">REPLACE</p> <p>E3234 L1606</p> <p>Dia.Ext. Dia.Int. Long. 1-5/16" 1-1/32" 1/8"</p> <p>46-3-043 DIA. 1-1/2"</p>	<p style="text-align: center;">COUSSINET NYLON</p>  <p style="text-align: center;">REPLACE</p> <p>E2408 L1296 1225B834</p> <p>Dia.Ext. Dia.Int. Long. 1-7/8" 1-5/8" 1-1/8"</p> <p>46-1-060</p>	<p style="text-align: center;">TUBE ACIER</p>  <p style="text-align: center;">REPLACE</p> <p>Dia.Int. 1-1/2" Dia.Int. 1-7/8" Dia.Int. 1-3/4" Dia.Int. 1-5/16"</p> <p>46-1-058</p> <p style="text-align: center;">GOUPILLE</p>  <p>46-1-037 5/16" x 1-3/4"</p>	<p style="text-align: center;">JOINT</p>  <p style="text-align: center;">REPLACE</p> <p>E2505 120U1451</p> <p>Dia.Ext. Dia.Int. Long. 2" 1-5/8" 3/16"</p> <p>46-1-063</p>
<p style="text-align: center;">RONDELLE</p>  <p style="text-align: center;">REPLACE</p> <p>E656 L202 29-1310 1229G1463 1229L844</p> <p>Dia.Ext. Dia.Int. Long. .060" 1-17/32" 3-7/8"</p> <p>46-1-047 DIA. 1-1/2"</p>					

FREIN

SOUPAPE DE FREIN - BENDIX

SORTIE VERTICALE			SORTIES VERTICALE ET HORIZONTALE			SOUPAPE DE RELAIS PILOTE			SOUPAPE DE RELAIS		
											
R-12	POINT D'OPÉRATION	SORTIE	R-12	POINT D'OPÉRATION	SORTIE	R-12-P		SORTIE	R-14H	POINT D'OPÉRATION	SORTIE
BW-065104	4lbs/po.carré	3/8	BW-065206	5.5	3/8	BW-065476		3/8	BW-103010	4lbs/po.carré	1/2
RELAIS D'URGENCE			SOUPAPE DE RELAIS			SOUPAPE DE FREINS À RESSORT			SOUPAPE DE PROTECTION		
											
RE-6	POINT D'OPÉRATION	SORTIE	R-8		SORTIE	SR-5		SORTIE	PR-4	POINT D'OPÉRATION	SORTIE
BW-281865	5.5	3/8	BW-286370		1/2	BW-065437		3/8	BW-286500	85lbs/po.carré	1/4
SOUPAPE DE FREINS À RESSORT			SOUPAPE DE FREINS À RESSORT			SOUPAPE DE CONTRÔLE			SOUPAPE À PIED		
											
SR-1	POINT D'OPÉRATION	SORTIE	SR-2		SORTIE	PP-1	POINT D'OPÉRATION	SORTIE	E-6		SORTIE
BW-286364N	55lbs/po.carré	1/4	BW-287376		3/8	BW-276566	20lbs/po.carré	1/8	BW-286171		3/8
ÉCHAPPEMENT RAPIDE			ÉCHAPPEMENT RAPIDE								
											
IPSI QR-1	ENTRÉE	SORTIE	QR-1C		SORTIE						
BW-229859	3/8	3/8	BW-289714		3/8						
BW-229860	1/2	3/8									

FREIN

SOUPAPE DE FREIN - HALDEX

SOUPAPE DE SERVICE



SOUPAPE DE RELAIS

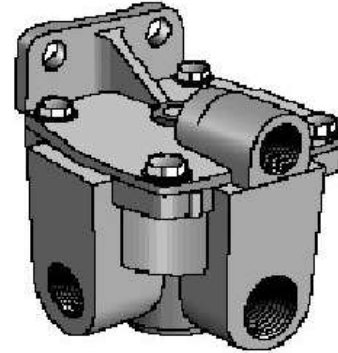

NO. PIÈCE		ALIMENTATION	SORTIE	SORTIE	HA-KN28520	RG-2	1/2	POINT D'OPÉRATION	
HA-B12352N		3/4	1/4	3/8	HA-KN28510	RG-2	3/8	5-6	

SOUPAPE DE RELAIS D'URGENCE



SOUPAPE MULTI-FONCTIONS



NO. PIÈCE	POINT D'OPÉRATION	ALIMENTATION	SORTIE	SORTIE	418-1-236		POINT D'OPÉRATION	ALIMENTATION	
HA-KN30400	3 lbs/po.carré	1/4	3/8	3/8	HA-KN28600	FF2	3	3/8	
					HA-KN28601	FF2	3	3/8	

SOUPAPE MULTI-FONCTIONS



SOUPAPE DE RELAIS PILOTE



NO. PIÈCE		POINT D'OPÉRATION	ALIMENTATION	SORTIE	NO. PIÈCE		POINT D'OPÉRATION	ALIMENTATION	SORTIE
HA-KN26000	RT4	55 lbs/po.carré	3/8	3/8	HA-KN28300		0 lbs/po.carré	1/2	1/2

FREIN

SOUPAPE DE FREIN - SEALCO

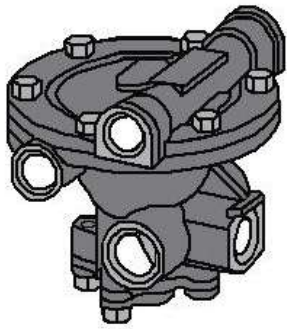

SL-110197

RELAIS

POINT D'OPÉRATION	SORTIE
4 lbs. po. carré	3/8 (2)

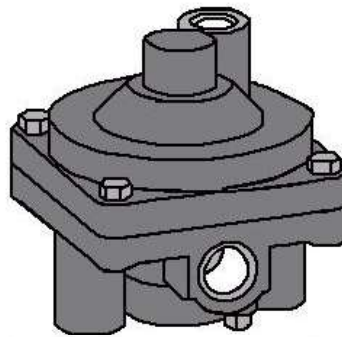

SL-110410

RELAIS

POINT D'OPÉRATION	SORTIE
4 lbs. po. carré	3/8 (2)

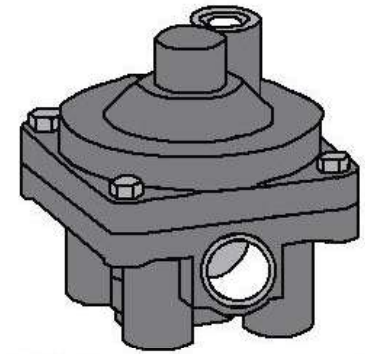

SL-110415

RELAIS

POINT D'OPÉRATION	SORTIE
4 lbs. po. carré	3/8 (4)

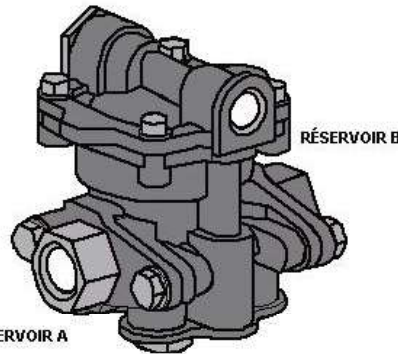

SL-110139

RELAIS

PT.D'OPÉRATION	ALIMENTATION	SORTIE
4-5 lbs.po.car.	3/8	3/8 (4)

SL-110170

RESSORT

PRIORITÉ AUXILIAIRE	ALIMENTATION	SORTIE
chambre de frein	3/8	3/8 (4)

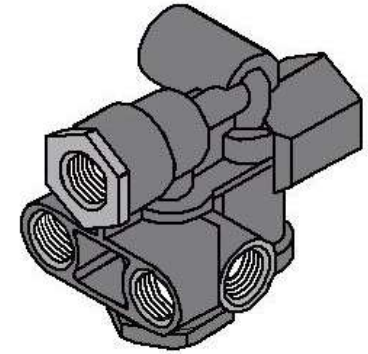

SL-110500

RESSORT

PT.D'OPÉRATION	PRIORITÉ AUX	ALIMENTATION	SORTIE
80 lbs.po.car.	chambre de frein	3/8	3/8 (4)

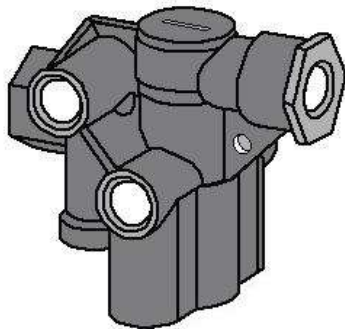

SL-110800

RESSORT

PT.D'OPÉRATION	PRIORITÉ AUX	ALIMENTATION	SORTIE
80 lbs.po.car.	chambre de frein	3/8	3/8 (4)

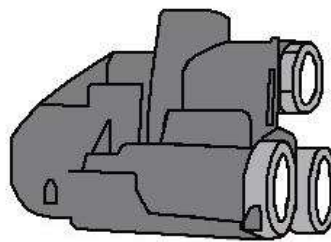

TR-51301

RESSORT

TEV	PRIORITÉ AUXILIAIRE	ALIMENTATION	RÉSERVOIR
TRAMEC	chambre de frein	1/4	3/4

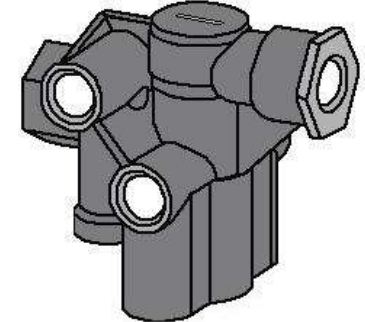

SL-110700

RESSORT

PT.D'OPÉRATION	PRIORITÉ	ALIMENTATION	SORTIE
80 lbs.po.car.	RÉSERVOIR	3/8	3/8 (4)

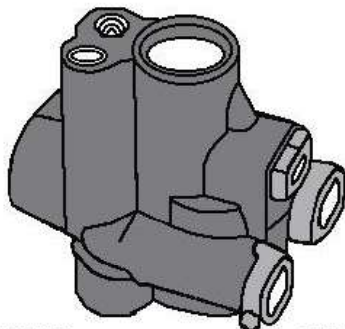

TR-51321

RESSORT

STEV	PRIORITÉ
TRAMEC	RÉSERVOIR